

Policy No.: _____

Insured: _____

Agent: _____

Location of Risk: _____

**WOOD/COAL BURNING FACILITY
QUESTIONNAIRE**

REQUIREMENTS

1. A photo of the wood/coal burning facility must be submitted with this Questionnaire.
2. Questionnaire and photo must be submitted with application for insurance.
3. Questionnaire must be inspected and signed by a licensed contractor or member of local fire department when facility is NOT factory installed or commercially installed by appliance distributor or licensed expert.

STOVE INFORMATION

TYPE	<input type="checkbox"/> Radiant <input type="checkbox"/> Circulating <input type="checkbox"/> Franklin <input type="checkbox"/> Other (specify):		
MAKE/NAME	By: _____	U.L. Approved? <input type="checkbox"/> Yes <input type="checkbox"/> No	
USE	<input type="checkbox"/> Primary Heat <input type="checkbox"/> Auxiliary Heat <input type="checkbox"/> Cooking <input type="checkbox"/> Other (specify):		
INSTALLED	By: _____	Date: _____	
FLOOR PROTECTION	<input type="checkbox"/> Asbestos Millboard Covered with Metal <input type="checkbox"/> Metal <input type="checkbox"/> Stone/Brick <input type="checkbox"/> Other (specify below)		
WALL PROTECTION	<input type="checkbox"/> Asbestos Millboard Covered with Metal <input type="checkbox"/> Metal <input type="checkbox"/> Asb. Millbrd <input type="checkbox"/> Other (specify below)		
CHIMNEY & STOVE PIPES	CHIMNEY TYPE: <input type="checkbox"/> Factory <input type="checkbox"/> Masonry <input type="checkbox"/> Other (describe):		
	How often checked for creosote build-up?		
	Date Last Cleaned: _____		By Whom? _____
	Does vent pass through a combustible partition? <input type="checkbox"/> Yes <input type="checkbox"/> No		
	If yes, is protection thimble or sleeve used? <input type="checkbox"/> Yes <input type="checkbox"/> No		
	Does pipe vent pass directly through the roof? <input type="checkbox"/> Yes <input type="checkbox"/> No		
Are any other heating units vented to chimney? <input type="checkbox"/> Yes <input type="checkbox"/> No (describe below)			
Is stove vent system equipped with heat reclaiming unit or flue radiator? <input type="checkbox"/> Yes <input type="checkbox"/> No			

CLEARANCES

1. Side of unit to nearest wall inches.
 2. Rear of unit to wall inches.
 3. Top of stovepipe to ceiling inches.
 4. Bottom of unit to floor inches.
 5. Front of unit to front edge of floor protection inches.
 6. Size of stovepipe used inches.
 7. Size of thimble or roof joist shield inches.
- Do these distances comply with the manufacturer's standards? Yes No

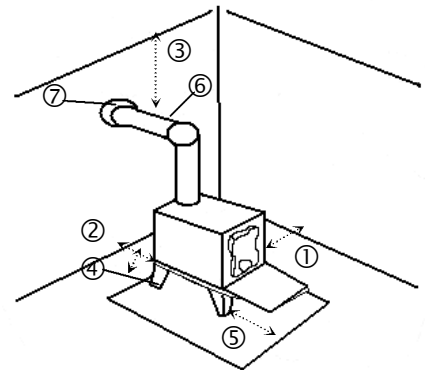

MISCELLANEOUS

FUEL	<input type="checkbox"/> Wood <input type="checkbox"/> Coal <input type="checkbox"/> Other (specify):		
PREVENTION	Fire Extinguisher in Room? <input type="checkbox"/> Yes <input type="checkbox"/> No	Smoke Alarm? <input type="checkbox"/> Yes <input type="checkbox"/> No	
ADDITIONAL REMARKS			

Inspector Signature: _____

Date Inspected: _____

PHOTO MUST BE ATTACHED